



## **Life Time**

Polypropylene capacitors in 9 micron quality are the guarantee for long life expectation. The compact internal logic and switch circuitry is epoxy resin protected against moisture and dust. Electric, magnetic and electrostatic disturbances, over- and undervoltages and short circuits are covered by EMI filters and oversized semiconductors. Solid-state switches used in a Booster are high-voltage high-current semiconductors, tested for 2200V and made to withstand (short circuit) currents of up to 2250A (in a 16 kW Booster).

The bearings of the internal motor-generator are greased for life-time.

## **Loads**

There are machines which are an easy loads for a converter e.g. mills, drills, saws, grinders etc. There are other applications where a Booster will perform better than any other converter: refrigeration systems, hydraulic machines, printing presses, wide-belt sanders, heavily loaded water pumps, planers, conveyors, lifts, thicknessers, air compressors, dust collectors, high-speed high-volume fans, vacuum pumps. Metal lathes without clutch, with a high speed spindle (over 750 rum) and possibly an older and inefficient type of motors, are very demanding. High-speed lathes that start under full load require high starting torques. A Booster E will cope with all these hard-starts.

In case of hard-start conditions, some manufacturers of phase converters suggest to use a converter twice the size of the operated motor. This is not the case with our Booster. The kw size quoted will start a machine of the same kw.

## **Supply Cable**

A Booster E4 under full 4 kw load will draw about 18A from the 230V supply line. When machines or motors start, immediately the boost-mode is activated. Depending on the load and on the quality of the supply line, the input current will go up to 50-60A. If the supply cable is weak, voltage drop will occur at the input side, especially when loads are increased. The same relative voltage drop will be found at the converters output: Motors will finally not accelerate as fast as they should, motors will not cope well with high loads. It is essential to use a well sized or better oversized single-phase supply cable.

Extreme hard-starts will occur with applications like refrigeration systems, compressors, metal lathes, hydraulic systems, welders, wheel balances.... An even better supply cable is essential.

A Booster should always be mounted as close to the single-phase service as possible.

## **What to expect from a Booster**

Boosters are versatile and powerful and are a viable option to three-phase power supplied by an electricity company. They can be compared to a generator set. Instead of a diesel or petrol motor the driving power comes from the input supply line. The quality of the Booster's three-phase output depends much on the quality and stability of the single phase input line. If the supply voltage does not change with loads, this can be compared to a gen-set with a motor running at constant speed. Motors connected to Boosters will accelerate fast as long as the voltage drop on the supply side is kept low. Low input or output voltages will reduce the efficiency and the output power of motors and machines connected to it. Boost-mode, the capability to start motors under load, is made electronically. Like a generator which, for a brief moment, became five times bigger.

Remember a utility supplied three-phase power often brings higher electrical tariff costs than a Booster -- after all someone has to pay the purchase and maintenance cost of the extra lines and extra street transformers.

A Booster is owned by you. It is 100 percent tax deductible for your business. You can take it to a new location. It can be turned off when you don't need it and you're not paying any line charges.

### **Welders**

Three-phase welders are designed for a duty cycle (welding time divided by total time). If you overload a welder the internal overload switch will trip after some time. Boosters can also be overloaded for a short period of time. But Boosters don't have overload switches. In case of short overloads, make sure you protect your Booster by the right kind of motor rated fuse in your switchboard.

We have seen customers successfully using a Booster E8 running a 330A welder which had an input power of about 12kW when welding. Under these conditions input currents into a Booster E8 would be 50-60A compared to the nameplate limit of 40A. This might be acceptable as long as a Booster is given time to cool down by running idle for at least as long as it has been used under excessive load.

Whilst we do not recommend you to overload a Booster, the above sample is used to show that a Booster would overheat if a user does not follow instructions and uses wrong fuses.

Find the right Booster for welding: Multiply the weld currents by 50 (E series) or 25 (D series) to determine the size of a Booster needed for welding at 100% duty circle (continuous operation) e.g. a 300A welder at 100% duty cycle =  $300 \times 50 = 15000W$ : a Booster E16 will do the job.

### **Irrigation Pumps**

Some farms are without three-phase electricity supply.

The cost efficient and dependable way to operate an irrigation system is with a Booster.

The local electricity supply company would supply either 400V two-phase or 460V dual voltage. Larger Boosters require these higher input voltages in order to keep supply currents low. You have to specify the input voltage when ordering a Booster.

Your Booster size is calculated by adding the total horsepower of pivot, pump, and the end gun motors that you wish to operate. Then divide the result by 1.34 and you will find the Booster's kw that matches your requirement e.g.  $5hp + 7hp + 4hp = 16hp = 11.94kW$ . Use a 12kW Booster.

Install a heavier supply cable when windshield-wiper type (reversing) pivots are used. Your Booster will often go into boost-mode.

### **EMC, RFI and Safety**

Electromagnetic radiation and line disturbance is kept low and within legal limits. Boosters comply with EMI, RFI and safety regulations.

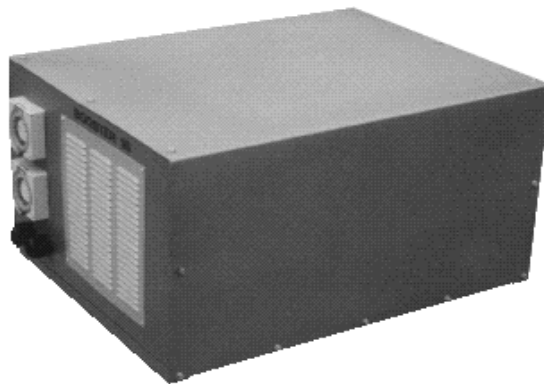

## For the Electrician

Boosters are made for either 220-240V single-phase single voltage inputs or for 380-415V two-phase or for 440-480V dual voltage inputs. These voltages are often used on farms. By doubling the input voltage you reduce the required input currents and the cable sizes needed by 50%.

The single voltage version:

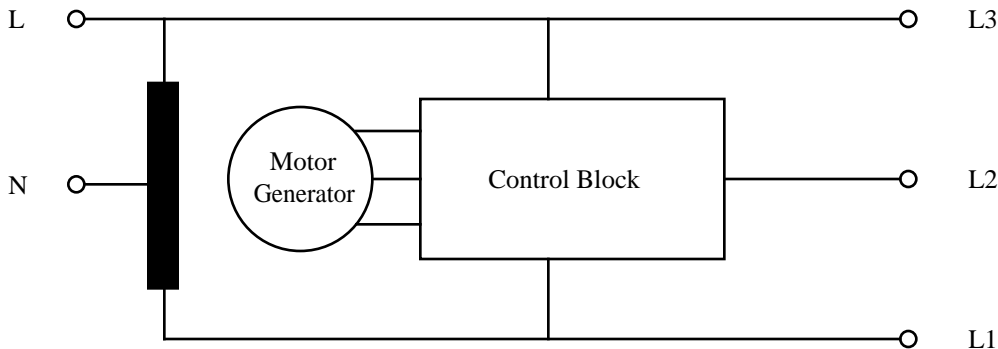

The dual-voltage and two-phase version:

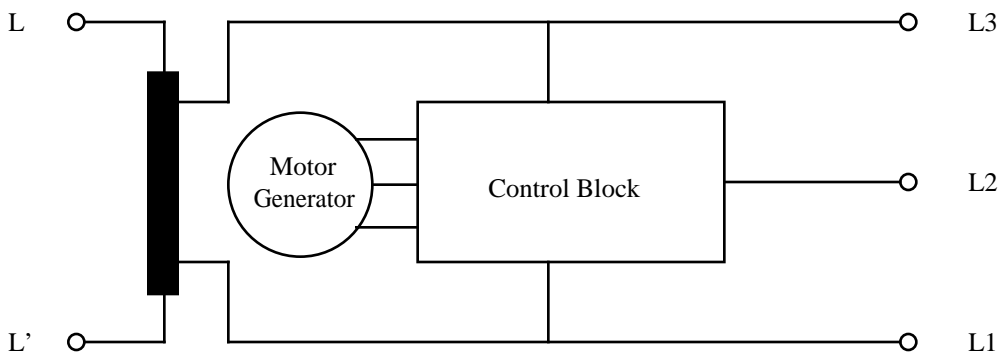

As you can see, Boosters are made for three-phase loads only. If loads need to be connected between one of the output phases and Neutral: use L3 only.

The three phases are not produced related to Neutral. Sinewave is symmetrically produced between the phases (3 x 120 degrees phase shift). Do not measure voltages between one of the phases and Ground or Neutral. Always check voltages between the three phases.

As with a generator set, voltages between phases are a bit higher without load and a bit lower under full load. This is normal.

Machines and welders using internal control transformers:

Voltages between L2 and one of the other phases are more subjects to fluctuations than between L1 and L3. Use L1 and L3 for control transformers in any machine.

How to find out how a control transformer is connected: In off-position, measure the resistance between the phases of a machine's plug. Transformers may show some Ohm to a few hundred Ohm. If it is not L1 and L3, rotate connections in the machine's plug until these conditions are met.

Some of the so called three-phase transformer-type welders are actually 380-415V single-phase welders. Connect them to L1 and L3.

When using an inverter type welder, make sure this converter is specified to run on generators. This will guaranty successful operation with a Booster.